

Small Enterprise Environment Monitoring System

ENVIROMUX®

SNMP and Web monitoring/management of server room environments. Provides early warnings before critical events turn into disaster.

Environment Monitoring

- Remote Temperature/ Humidity Sensors over IP
- Temperature
- Humidity
- Water Leaks
- Air Flow
- Power
- Motion / Intrusion
- Vibration
- Smoke / Carbon Monoxide

Alert Notifications

- Email
- SNMP
- Webpage
- Voice Phone Calls
- SMS Messages
- Front Panel LEDs

Key Features

- Supports NTI's advanced sensors which can be extended up to 1,000 feet using Cat5/5e/6 cable
 - Sensors are hot pluggable
- Monitor (ping) up to 64 IP network devices – alerts are sent if devices are not responding
- Sensor conditions (events) can be configured to trigger alerts by themselves, and/or be used in combination with other events to trigger Smart Alerts.
- Integrates with various Open Source monitoring packages – Nagios and MRTG
 - The unit can be polled via SNMP.
- Optional battery backup – alerts are sent when there is a power outage and when power returns
- Available with dual redundant power for connection to two separate power sources. (The second power supply is sold separately.)
- Available with optional 24VDC power.
 - Comes with a 24V DC-DC power converter built inside the unit.
- Optional industrial small environment monitoring system for high temperature environments. This industrial system has the ability to operate and monitor in harsh environments at high temperatures up to 167°F (75°C).
- Cascade up to 5 units via Ethernet connection (1 master, 4 slaves) to increase the number of sensors connected.
- USB ports for connecting USB modem or for downloading log data to USB flash drive
- Flexible Zero-RU mounting; optional DIN mounting or 1RU rack mount kit available
- Multi-language support – English, German, Chinese, and Japanese.
- Linux inside



E-2D (Front & Back)

- **Configure Smart Alerts for different event combinations**
- **2 external configurable sensors, 5 digital inputs, 1 output relay**
- **User-programmable IP camera snapshots**
- **Linux inside**
- **Cascade up to 5 units via Ethernet connection (1 master, 4 slaves)**

The ENVIROMUX® Small Enterprise Environment Monitoring System monitors critical environmental conditions (such as temperature, humidity, and water leakage) that could destroy network components in your server room. When a sensor goes out of range of a configurable threshold, the system will notify you via email, SNMP traps, web-page alerts, a visual indicator (red LED), voice phone calls (via Automatic Voice Dialer System), and SMS messages (via email-to-SMS or external USB modem).

The system supports two external configurable sensors, five digital input sensors, and one output relay for control of external devices.

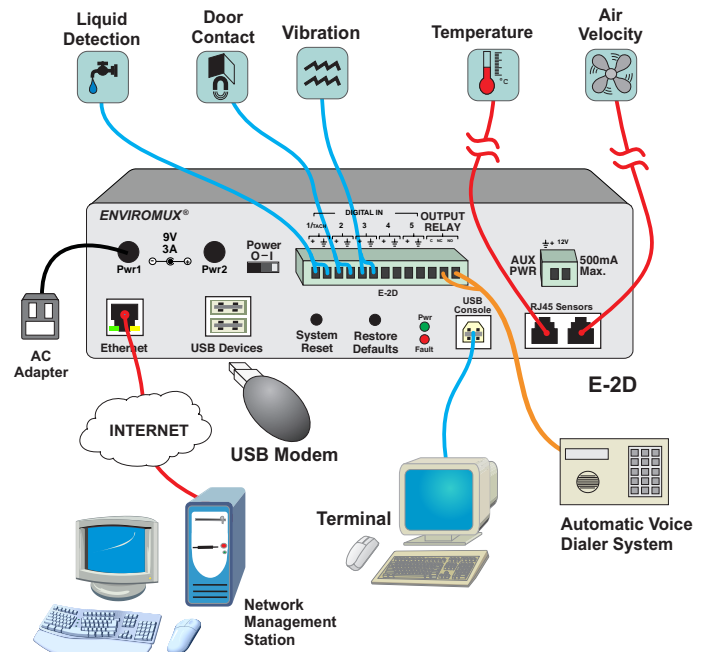

Ideal for data centers, co-lo sites, web hosting facilities, telecom switching sites, POP sites, server closets, or any unmanned area that needs to be monitored.

Small Enterprise Environment Monitoring System

ENVIROMUX®

SNMP and Web monitoring/management of server room environments. Provides early warnings before critical events turn into disaster.

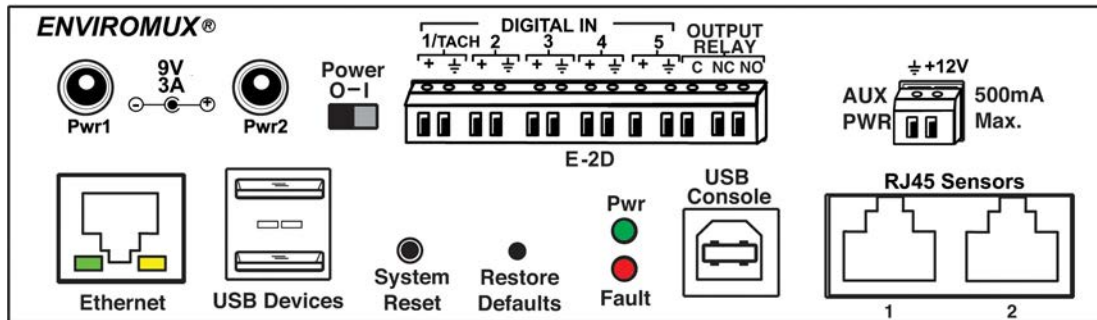

	E-2D
RJ45 Sensor Ports	2
Digital Inputs – Screw Terminal Pairs	5
Output Relays – Screw Terminal Pairs	1
Remote Temp/Humidity Sensors over IP	8
Remote 1-Wire Sensors over IP	4
Auxiliary (12V) – Power Terminal	✓
Alerts	7 methods
Email	Authenticates
Web Page	✓
SNMP traps (v1,v2c,v3)	✓
LEDs	2 (Power, Fault)
Alarm beacon/Siren	Can be connected (using output relay)
Voice Phone Calls	✓- via Automatic Voice Dialer System (not included)
SMS Messages	✓- via external USB modem (not included)
Smart Alerts	✓
Control Methods	5 methods
Web Interface	✓
Telnet	✓
SNMP Monitoring (v1,v2c,v3)	✓
SSH	✓
USB-to-Serial Console	✓
USB Ports for Modem and Data Logging	2
Expandable/Cascade	Up to 5 units via Ethernet connection (1 master, 4 slaves) Up to 3,000 units via optional management software
Flash Upgrade	✓
Linux Inside	✓
Restore Defaults Button	✓
System Reset Button	✓
Protocols Supported:	HTTP/HTTPS, SNMP V1/V2c/V3, SMTP, TCP/IP, Syslog, SNTP, DHCP, SSHv2, SSLv3, TLS v1.2, LDAPv3, XOAuth2, AES 256-bit, 3DES, Blowfish, RSA, EDH-RSA, Arcfour, IPV6, WAP 2.0, RADIUS
Languages Supported:	English, German, Chinese, Japanese
Operating Temperature	E-2D: 32 to 140°F (0 to 60°C) E-2D-IND: -4 to 167°F (-20 to 75°C)
Storage Temperature	-22 to 140°F (-30°C to 60°C)
Operating & Storage Relative Humidity	5 to 90% non-condensing RH
Backup Battery	Optional - up to 2 Hours
Monitor (Ping) IP Devices	✓- up to 64 network devices
Power	100 to 240 VAC at 50 or 60Hz via AC Adapter Options: Dual DC Power, 24VDC
Dimensions WxDxH (in)	5.82x3x1.75
Mounting	Zero-RU - mounting tabs included Optional 1RU mounting kit Optional DIN rail mounting kit
Regulatory Approvals	CE, RoHS
Warranty	2 years